

## Case Study

# Industrial Water Treatment

Sediment Treatment Tank, Barry Road, Campbellfield, Victoria  
Project Manager: Centre for Environmental Stress and Adaptation Research

The Toxic Treatment Facility (TTF) was designed to compare the performance of filtration media in removing pollutants from stormwater. It is located at Barry Rd, Campbellfield, Melbourne, Victoria. Stormwater first passes through a Gross Pollutant Trap and then to a flow splitter where it is discharged into three 1m<sup>3</sup> treatment tanks constructed in parallel to enable direct comparative performance of three filtration media. When inflow volumes exceed the capacity of the TTF, water flows over the diverter into the main drain and directly into the creek. For the reported data, pollutant concentrations, flow volumes and physiochemical parameters were measured at the inlet to the TTF and at the outlet from the three treatment tanks as shown in Figure 1. The site of the device is shown in Figure 2.

## Major Findings

Parameter	Enviromedia blend 4		Enviromedia blends 1-3	
	Inflow (Mean)	Outflow (Mean)	Inflow (Mean)	Outflow (Mean)
Total Zinc (µg/L)	699 <sup>^</sup>	290 <sup>^</sup>	802 <sup>#</sup>	546 <sup>#</sup>
Total Lead (µg/L)	14 <sup>^</sup>	11 <sup>^</sup>	19 <sup>#</sup>	15 <sup>#</sup>
Total Copper (µg/L)	23 <sup>^</sup>	11 <sup>^</sup>	36 <sup>#</sup>	27 <sup>#</sup>
Total Phosphorous (mg/L)	0.50 <sup>^</sup>	0.42 <sup>^</sup>	3.5 <sup>#</sup>	3.0 <sup>#</sup>
C <sub>10</sub> -C <sub>14</sub> (µg/L)	-	-	486 <sup>^</sup>	256 <sup>^</sup>
C <sub>15</sub> -C <sub>28</sub> (µg/L)	-	-	3725 <sup>^</sup>	1425 <sup>^</sup>
C <sub>29</sub> -C <sub>36</sub> (µg/L)	-	-	2109 <sup>^</sup>	629 <sup>^</sup>
Total Petroleum Hydrocarbon (µg/L)	-	-	6395 <sup>^</sup>	2310 <sup>^</sup>

<sup>^</sup> 3 sample events over 77 days

<sup>#</sup> Average readings for 3 tanks for 13 sample events over 98 days

Table 1. Stormwater treatment data from treatment tank study

The study by Marshall et al (2006) concluded that the Enviromedia blends were the most effective out of the tested materials in treating the metals and hydrocarbons. Various other filtration media were prone to clogging or leaching. An analysis of the monitored stormwater inflow over the 13 events showed that most of the metals occurred in a dissolved form rather than a particulate bound form. The percentage of the contaminants in a dissolved form was zinc (53%), copper (63%), lead (45%) and phosphorous (78%). This highlights the need to have a media that can remove dissolved contaminants in addition to particulate bound metals. The limited data from the Enviromedia 4 trial (unpublished data) suggests that it had an enhanced capacity to remove dissolved metals. This may be related to the greater thickness of the filtration media and the composition of the Enviromedia blend.

## Reference for the Study

- Marshall, S., Pettigrove, V. & Kearns, J (2006) A toxicant treatment facility for the field evaluation of filtration media for urban stormwater treatment, 7th International Conference on Urban Drainage Modelling and the 4th International Conference on Water Sensitive Urban Design, Melbourne, Australia, 2-7 April 2006.
- Raw data provided by S. Marshall.

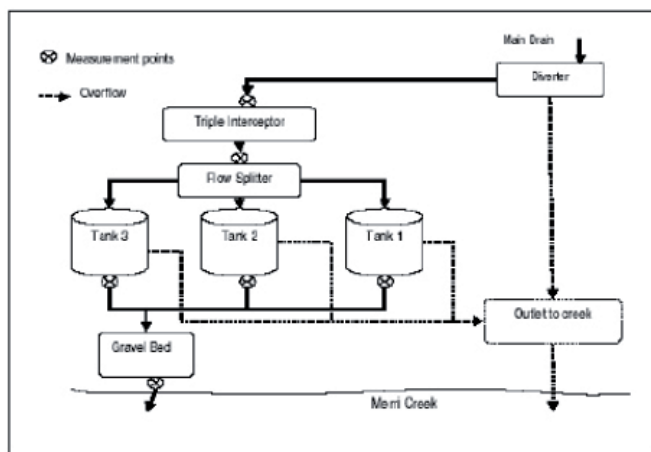

Figure 1. Schematic of the Toxicant Treatment Facility (After Marshall et al, 2006)

The study reported contaminant removal performance for various filtration media including peat, perlite, peat/perlite blend, loamy soil and various amended media (Enviromedia). Only the data from the Enviromedia amended filtration media are reported here.



Figure 2. Treatment tanks at Toxic treatment Facility

The Enviromedia blends 1 to 3 contained 15-20% by volume specified organic material, coarse sand, aggregate and minerals, while Enviromedia Blend 4 contained 30% by volume specified organic material. In this report the performance data for Enviromedia blends 1-3 have been amalgamated due to their similarity in composition. For Enviromedia blends 1, 2 and 3 the media thickness in the treatment tank was 300mm while for Enviromedia 4 it was 800mm.